

Industrial

Portfolio and Tailormade Converter Control Boards

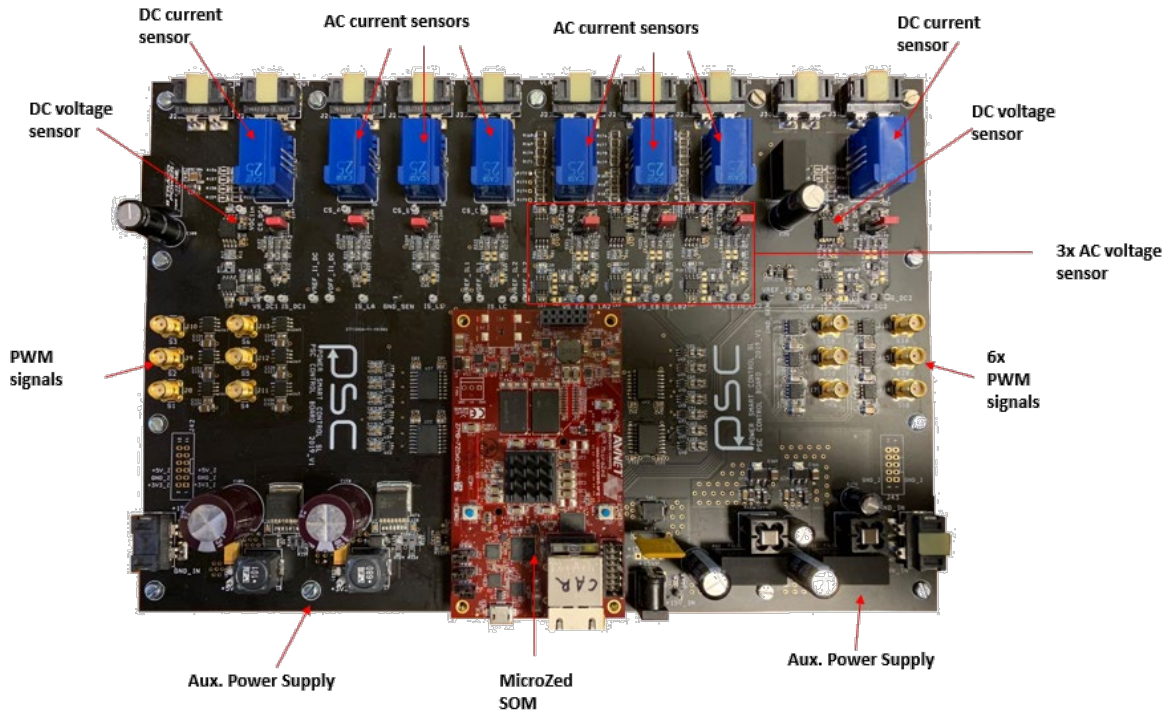

The fastest and non iterative solution for your new converter control system



PWM **modulation features** are **fully controlled** as they are defined in C or VHDL



Fully **flexible coding**: C/C++ for ARM microprocessors and VHDL/Verilog for FPGA



Remote Controlling and **FW update** capabilities



Embedded **oscilloscope & datalogger** and advanced post-processing tools



Large collection of control IPs available in C & VHDL



Web Server operation available powered by Petalinux



Engineering & Consulting services available

Portfolio Boards – Ready to Acquire!

- Computational core based on **Xilinx Zynq 7000 SOC**
- Specially **ruggedized** designs immune to switching noise for **industrial applications**
- Options available with on-board or remote **sensors**
- All boards allow **remote controlling**, remote **monitoring** and remote **fw-update**
- Programable in **C/C++** and **VHDL**
- Huge collections of already made **control IPs** and **consulting services** fully available



Meet your goals
at first attempt
with us!

Tailormade Control Boards

- Computational core at the **edge of technology with Xilinx KRIA K26**: Huge FPGA + 6 high end ARM microprocessors
- Different design objectives: from **cost-effective** designs to **high end designs**
- Feasible, **noise immune** and efficient analog sensing chains design
- **Open-source** customized designs available
- C/C++ coding and VHDL programing
- Industrial communication protocols design experience
- **Highly experienced** design team.
- With power to perform:
 - Remote **controlling**
 - Remote monitoring (Oscilloscope and data-tracker)
 - Remote data-logger
 - Remote **fw-update**
 - Data post-processing (FFT)
 - Hardware in The Loop and **Digital Twin**
- Huge collections of already made **control IPs** and **consulting services** fully available



Power Smart Control SL
Avda. Gregorio Peces Barba, 1
28919 Leganes (Madrid), Spain



sales@powersmartcontrol.com

